

BELLOWS WITH FLANGE DIAGRAM

Date: _____ Job #: _____ Customer: _____

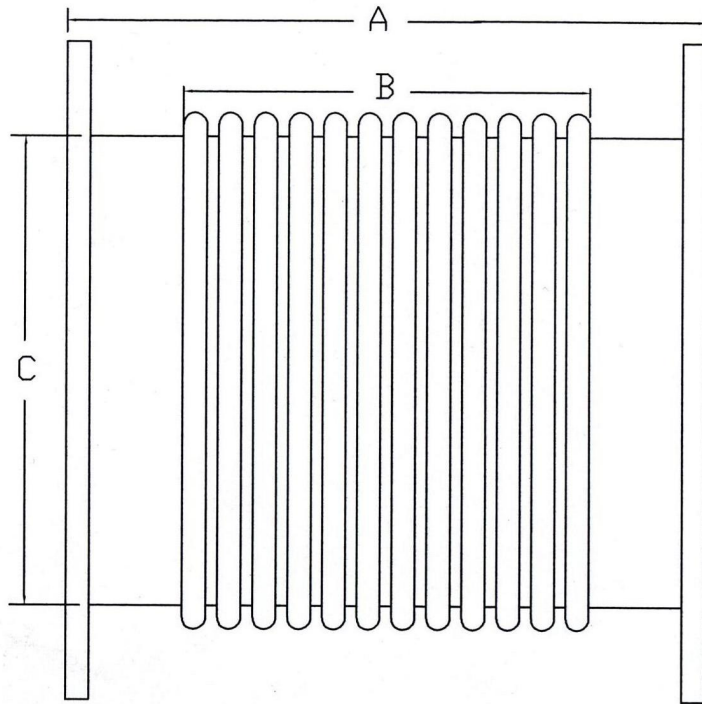

A	
B	
C	

	INLET	OUTLET
EXTENSION MATERIAL		
LENGTH		
FLANGE MATERIAL		
I.D.		
O.D.		
THICKNESS		
BOLT HOLES Dia.		
No.		
B.C.		

NOTES:

- 1.FLEX MATERIAL:
SINGLE PLY MULTIPLE PLY
- 2.PRESSURE:
- 3.LINER: NONE ONE TWO
- 4.BRAID: NONE ONE TWO
- 5.VANSTONE: NONE ONE TWO
- 6.FLOATING END: YES NO

BELLOWS DIAGRAM

Date: _____ Job #: _____ Customer: _____

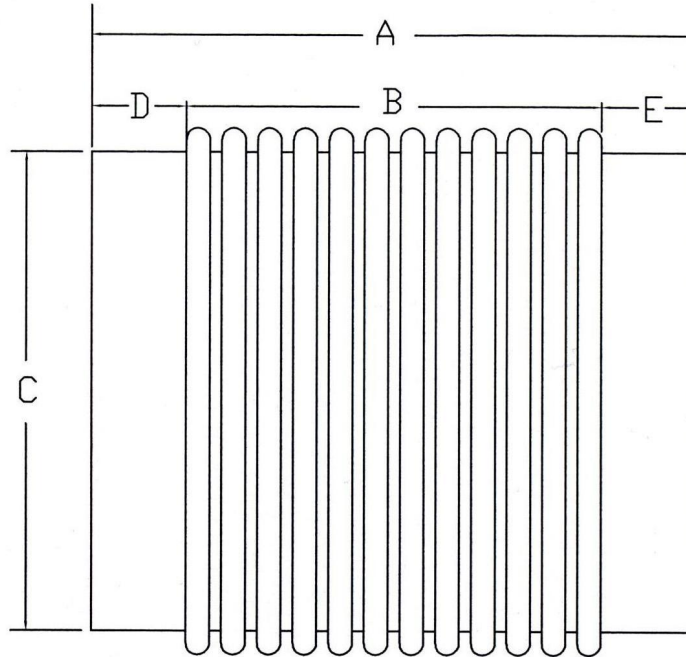

A	
B	
C	
D	
E	

- NOTES:
- 1.FLEX MATERIAL:
SINGLE PLY MULTIPLE PLY
 - 2.PRESSURE:
 - 3.LINER: NONE ONE TWO
 - 4.BRAID: NONE ONE TWO
 - 5.VANSTONE: NONE ONE TWO
 - 6.FLOATING END: YES NO